

rothe erde[®] slew drives

Installation | Lubrication |
Maintenance

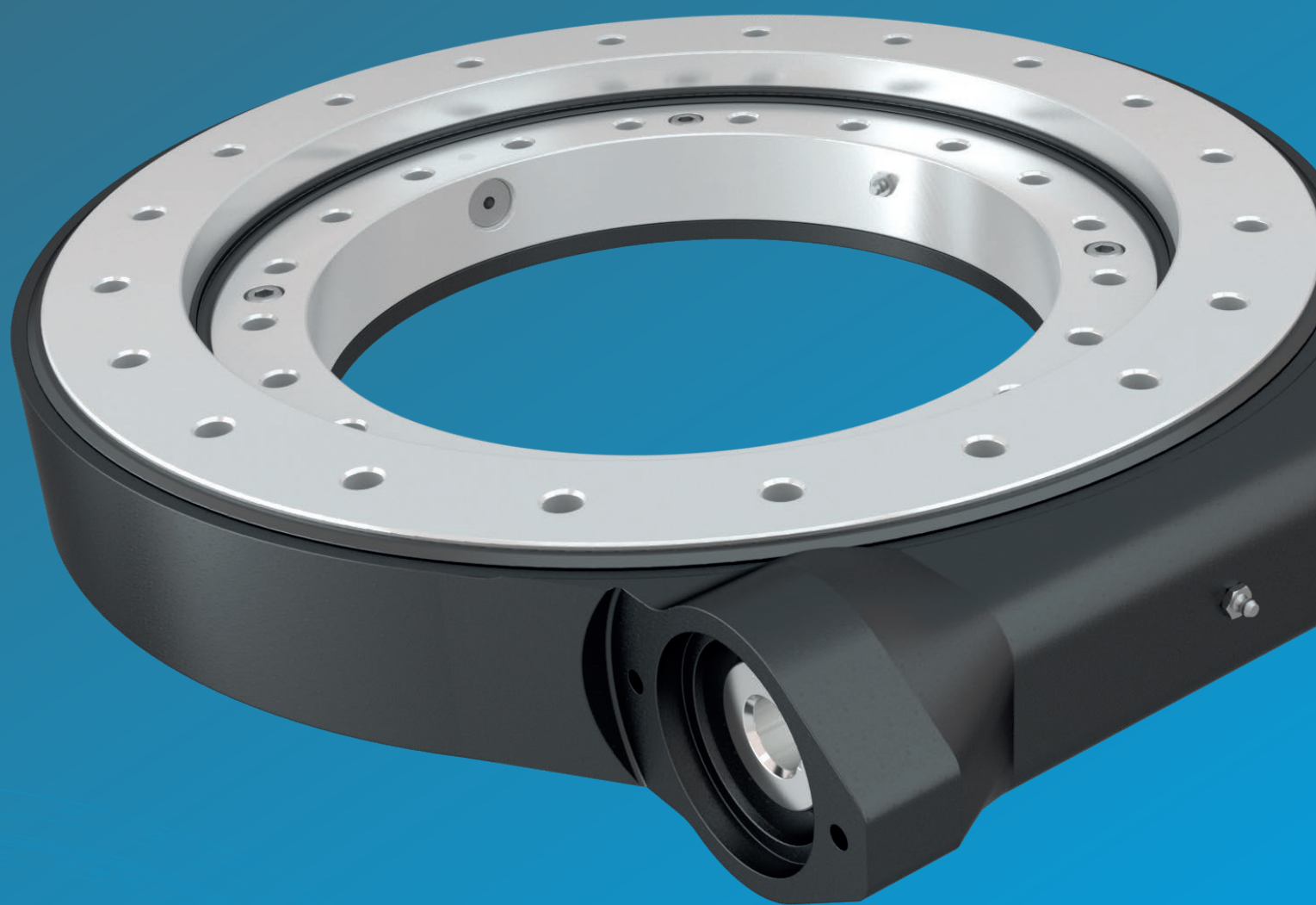

thyssenkrupp



rothe erde[®] slew drives –
developed for your application

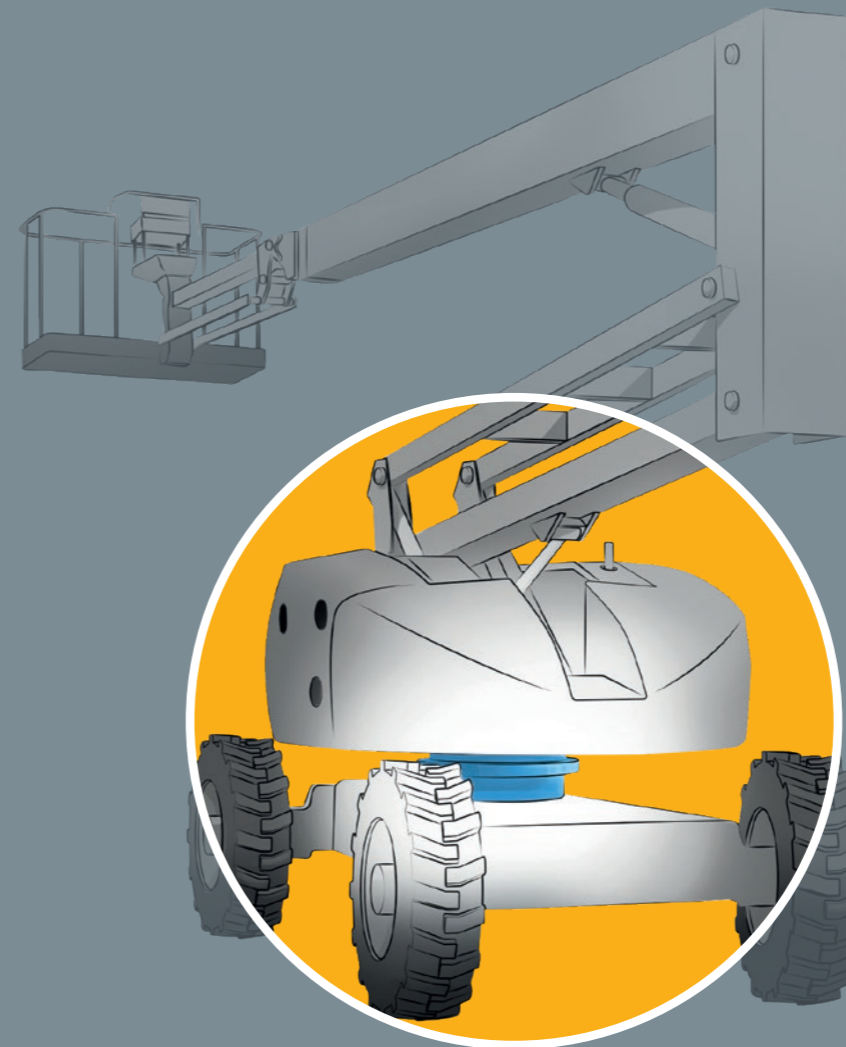

Installation, lubrication and maintenance (ILM) of slew drives

thyssenkrupp rothe erde Germany GmbH offers you comprehensive service,

including:

- ⊕ Installation and start-up,
- ⊕ Inspection and maintenance,
- ⊕ Replacement and repairs.

You can find more information and the thyssenkrupp rothe erde Germany GmbH range of training offers on our website at:

<https://www.thyssenkrupp-rotheerde.com/en/products/rothe-erde-slew-drives>

<https://www.thyssenkrupp-rotheerde.com/en/service/training-courses>

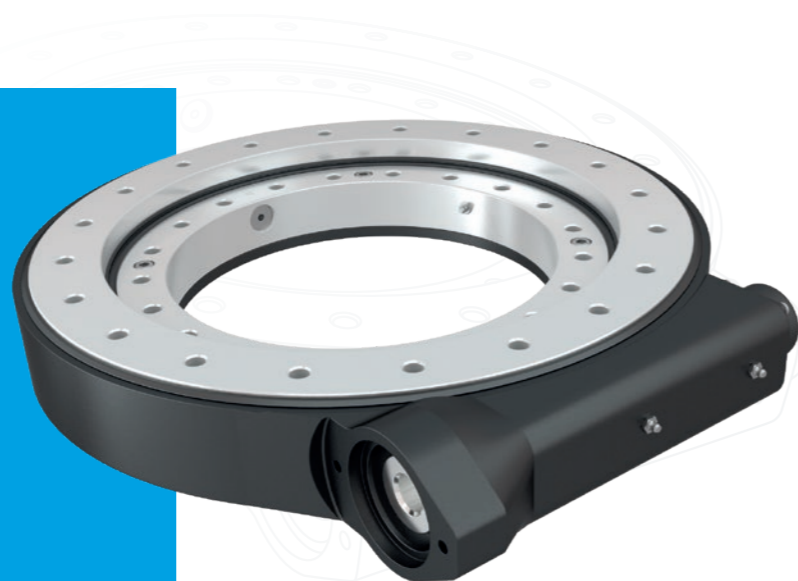

Contents

1.1 Transport and handling	6
1.2 Packaging and storage	7
1.2.1 Standard packaging	7
1.2.2 Long-term packaging	7
1.3 Installation	8
1.3.1 Preparation	8
1.3.2 Bolts	9
1.3.3 Operating temperature	9
1.3.4 Duty cycle	9
1.3.5 Start-up	9
1.3.6 Drive shaft and connecting flange variations	10
1.4 Lubrication	11
1.4.1 Slew drive lubrication	11
1.4.2 Lubrication interval	11
1.5 Inspection	12
1.5.1 Inspection of bolts	12
1.5.2 Inspection of sealing system	12
1.5.3 Inspection of raceway system	13
1.5.4 Inspection of worm gear's circumferential backlash	14
1.5.5 Lubricant analysis	14
1.6 Disposal at end of useful life	15
1.7 thyssenkrupp rothe erde services	15

1.1 Transport and handling

⚠ DANGER



Danger of death due to suspended load

- DO NOT stand under load
- Use appropriate attachment rigging
- Use appropriate lifting equipment
- Appropriate transport holes are shown in the bearing diagram

Slew drive types	Weight in kg	Thread size
SE 0224-L	46	M16
SE 0344-L	65	M16
SE 0422-L	87	M16
SE 0479-L	128	M16
SE 0626-L	220	M20

Table 1: Overview of weight and thread size of slew drive types

Like all machine parts, slew drives require careful handling. They must be transported using appropriate lifting equipment and attachment rigging. Avoid collisions as much as possible.

- Table 1 lists the weights of the individual slew drives (excluding packaging) and the thread size for inserting lifting/attachment rigging for each type.

1.2. Packaging and storage

- Slew drives must be stored in the horizontal position.
- The untreated contours of the slew drives (except fastening holes) are treated with the anti-corrosion agent CORTEC VCI.
- The slew drives are delivered in our standard packaging, including anti-corrosion agent.
- The storage requirements for standard packaging are described below.

WARNING



Sensitive surface

- Do not use a sharp knife to open the packaging
- Surface may be damaged

1.2.1 Standard packaging

Maximum permitted storage times:

Approx. 6 months: roofed storage areas

Approx. 12 months: closed, temperature-controlled rooms (temperature >12°C)

Storage periods longer than the standard times require long-term packaging!

During storage or for partially installed slew drives, please note the lubrication instructions (see section: Lubrication).

1.2.2 Long-term packaging

This special type of packaging is suitable if the slew drive needs to be stored for up to 5 years in closed and temperature-controlled >12°C rooms. The humidity should be checked every 6 months during the storage period.

Slew drives in long-term packaging are vacuum packed in a special foil with desiccant bags (silica gel) enclosed. A hygrometer is attached for checking the relative humidity (see table 2).

The long-term packaging includes a transparent cover with inspection instructions. The hygrometer is also located in this area. The customer should record the inspection result in an inspection report.

If the slew drive has been in storage for 5 years and the storage period is expected to continue, the slew drive must be inspected and the long-term protection/packaging replaced by thyssenkrupp rothe erde Germany GmbH or the box containing the slew drive must be returned to thyssenkrupp rothe erde Germany GmbH.

Please contact us with any questions or to arrange a date.



Hygrometer color change	Relative humidity	Comments
● blue	30%	OK
● violet	40%	OK
● pink or white	50%	Notify thyssenkrupp rothe erde Germany GmbH

Table 2: Hygrometer

1.3 Installation

1.3.1 Preparation

! WARNING	
	<p>Preservatives may cause skin irritation</p> <ul style="list-style-type: none"> • Wear gloves when removing • Please follow the manufacturer's instructions

If possible, the slew drive should be installed in the vertical rotation axis.

The mounting surface must be free of anti-corrosion agents. An alkaline cleaning agent can be used to clean the contact surface.

Note:

The preservative can easily be removed with, for example, a biodegradable alkaline cleaning agent.

Warning:

Do not let the cleaning agent touch the sealing or raceway! Do not paint the sealing!

The slew drive must be installed on a level, oil/grease-free surface of bare metal.

Please check that the contact surfaces for the slew drive are level. The maximum permitted deviation from levelness under DIN EN ISO 1101 is given in Table 3. Ball track \emptyset can be found in the model specifications. For example: SE 0244-L => ball track \emptyset 244 mm

Ball track \emptyset	Deviation from levelness under DIN EN ISO 1101
up to 500 mm	0.10 mm
up to 1000 mm	0.15 mm

Table 3: Permitted deviation from levelness of contact surfaces under DIN EN ISO 1101

Warning:

Do not allow peaks to form in small sectors, i.e. from 0°–180° the curve should only rise and fall once evenly.

! DANGER	
	<p>Danger of crushing when depositing the load</p> <ul style="list-style-type: none"> • Inspect the site before depositing • Be aware of co-workers

Hardness gap: The unhardened areas – “hardness gap” (stamped “S”) – of the ball slewing bearing must be arranged in the load-neutral area.

1.3.2 Bolts

When connecting the slew drive to the connecting structure, check that the fastening holes (slew drive/connecting structure) match.

If the fastening holes do not match, the slew drive may warp when the bolts are tightened. In the installation process, first connect the housing mounting surface to the connecting structure.

The slew drive's fastening bolts must be of strength grade 10.9 and hand tightened. Please use the specified number and diameter of bolts. Carefully tighten the bolts diagonally using a suitable tool (see Figure 1).

The interface pressure under the bolt head/nut may not exceed the permitted limits. If the interface pressure limit is exceeded, washers of suitable size and hardness must be used (see section “Bolts” in the rothe erde® Large Diameter Slewing Bearing catalog or download it at <https://www.thyssenkrupp-rotheerde.com/en/downloads/brochures-and-catalogues>)

Bolts 10.9	Preload force [kN]	Tightening torque
M16	115.7	338
M20	181	661

Table 4: Preload forces and tightening torques from VDI 2230

The above tightening torque assumes threads and nuts/head contact surfaces have been lightly oiled and that bolts and nuts do not have treated surfaces (total μ ges. = 0.140).

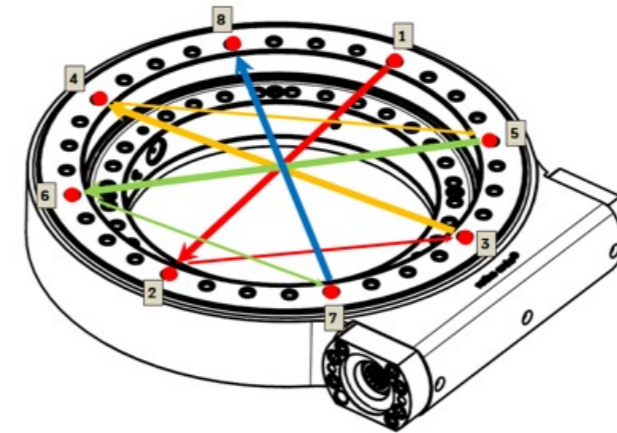

Figure 1: Correct order for tightening fastening bolts

After the first 20% of the bolts are tightened diagonally, all bolts must be tightened. As tightening the bolts affects the neighboring bolts, this should be done in at least two passes.

Warning:

Please check the bolt length in advance. At least 6 free thread turns must be available in the part of the bolt that is loaded (thread seat) to guarantee the minimum bolt penetration.

1.3.3 Operating temperature

The temperature range for the slew drive extends from -20°C to 60°C, assuming an even temperature distribution. If temperatures fall outside the permitted temperature range, steps must be taken to stay within it.

Please contact thyssenkrupp rothe erde Germany GmbH.

1.3.4 Duty cycle

Slew drives are designed for short-lasting loads. Overly long duty cycles lead to temperature increases and premature breakdown of the slew drive. A full load duty cycle of 10% of a minute must be followed by an appropriate cool-down period.

1.3.5 Start-up

The slew drive must be fully bolted together when started up. Please ensure that the slew drive cannot be damaged by current flow or equalization of potential during installation and operation.

1.3.6 Drive shaft and connecting flange variations

With key connection:

Bohrung für Motorwelle Ø25j6/k6
mit Passfeder A8 x 7 DIN 6885
Hole for motor shaft Ø25j6/k6
with fitting key A8 x 7 DIN 6885

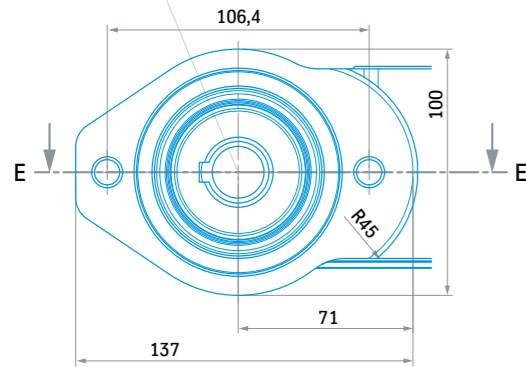

With spline shaft:

SE 0479-L

Evolventische Vielzahnnaabe (flacher Fuß)
Involute splined hub (flat root)
1 1/4"-ANSI B92.1

Toleranzklasse / Tolerance class: 5

N=14 / P/P_s=12/24 / Φ = 30°

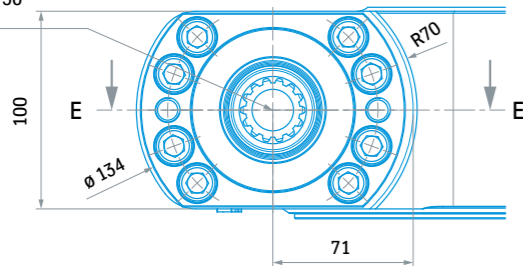

SE 0626-L

Evolventische Vielzahnnaabe (flacher Fuß)
Involute splined hub (flat root)
1 1/4"-ANSI B92.1

Toleranzklasse / Tolerance class: 5

N=14 / P/P_s=12/24 / Φ = 30°

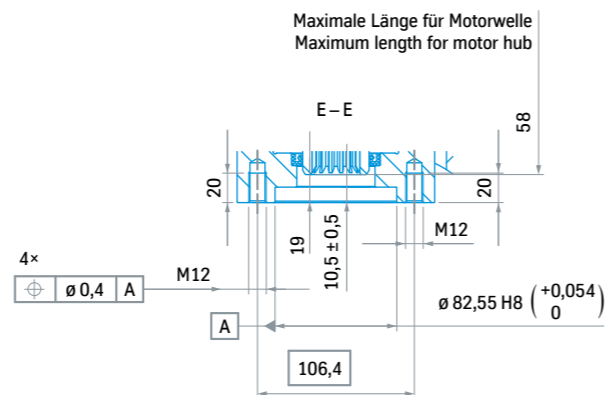
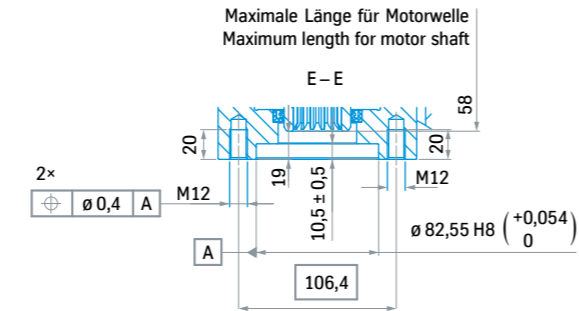
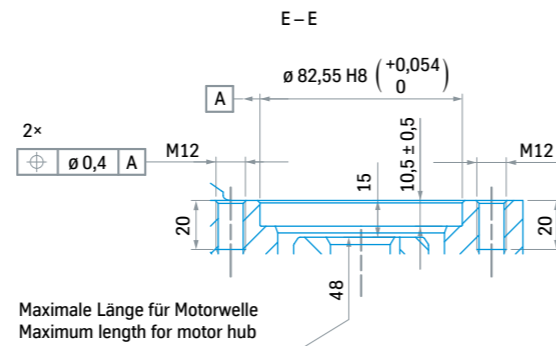
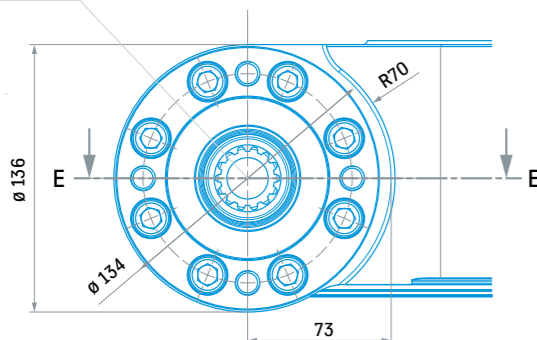

1.4 Lubrication

1.4.1 Slew drive lubrication

The slew drives are adequately lubricated with "Mobil UNIREX N3" grease on delivery. The grease filling reduces friction, protects against corrosion and is a component of the sealing. If using other lubricants, please obtain confirmation from the lubricant manufacturer that the product is suitable. Please also confirm with thyssenkrupp rothe erde that the lubricant is suitable and compatible with the plastic components.

Note: Lubricants are harmful to water. Do not allow them to escape into the soil, ground water or sewer system. Please comply with national regulations.

Please consult with thyssenkrupp rothe erde Germany GmbH if using an automatic lubrication system.

! WARNING	
	<p>Lubricants may be hazardous to health</p> <ul style="list-style-type: none"> • Wear gloves at a minimum when handling lubricants • Please follow the lubricant manufacturer's instructions

1.4.2 Lubrication interval

The first follow-up lubrication (using the grease named above) should take place on installation such that a visible collar of grease is formed on the seals.

Lubrication should be repeated after no more than 6 months, including for:

- Partially assembled slew drives,
- Slew drives before the equipment will be taken out of service or after it has been out of service for a longer period,
- Delayed start-up.

Lubricant should be applied while the worm drive is being turned.

The slew drive should be lubricated using the lubricating nipples shown in Figure 2 until a collar of fresh grease is formed along the full circumference of the seals. The old grease should be removed before each fresh application of lubricant.

The remaining lubricated connections in Figure 3 need only be lubricated with a small amount of grease.

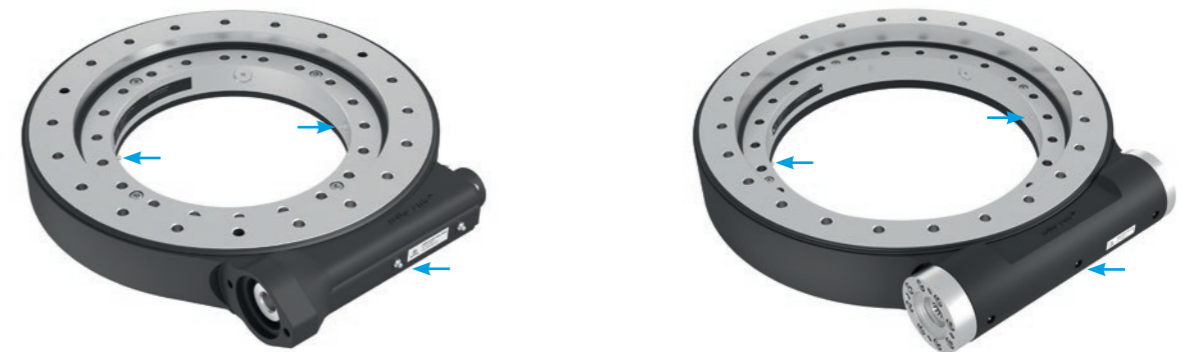

Figure 2: Position of lubricated holes -> slew drive

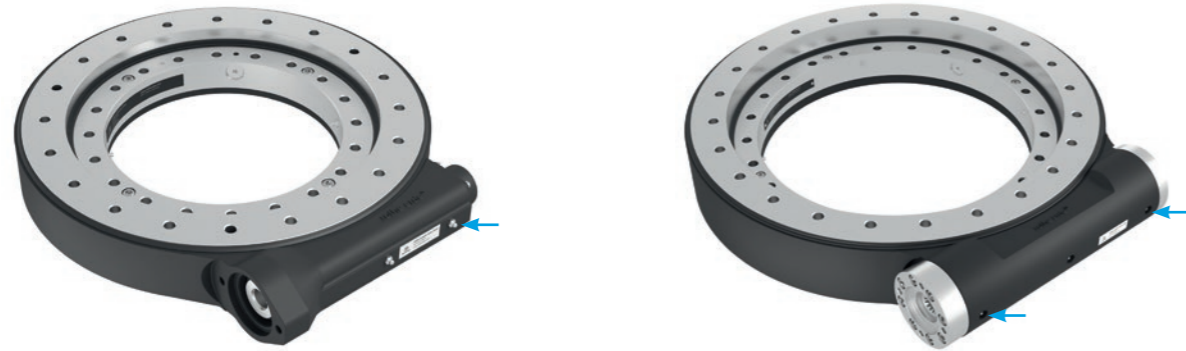

Figure 3: Position of lubricated holes -> worm bearing

Note:

Good lubrication is required for the raceway and gearing. It prevents dirt and moisture from penetrating the slew drive. The necessary service life of the application cannot be reached without lubrication.

Optimal use of lubricant and regular application increase system availability.

In partially installed slew drives, free metal contact surfaces must be adequately protected.

1.5 Inspection

1.5.1 Inspection of bolts

Please ensure that a sufficiently high bolt preload force is maintained over the full lifetime of the slew drive. Based on experience, tightening the bolts during regular lubrication to equalize subsidence is recommended.

1.5.2 Inspection of sealing system

Visible seals should be inspected at least every 6 months. Any dirt should be removed. Seals must be replaced if damaged.



Note:

When cleaning the equipment, please take care that no cleaning agent comes into contact with the seals or penetrates the raceway system.

Do not use pressure washers on the slew drive. This can damage the seals and allow water to penetrate.

The slew drive should be lubricated after any intensive cleaning (see section 1.4 "Lubrication").

1.5.3 Inspection of raceway system

 DANGER		
	<p>Risk of accident and danger of death if the maximum permitted wear limits are exceeded</p> <ul style="list-style-type: none"> The equipment should be decommissioned when the wear limits are reached 	
SAFETY ADVICE		
<ul style="list-style-type: none"> Please ensure that the bearing's wear limits are not reached during operation. For more information (diagrams/procedures), please see https://www.thyssenkrupp-rotheerde.com/de/service/lagerinspektion-und-wartung Wear should be ascertained and documented regularly The procedure for this is described in the manual Please contact thyssenkrupp rothe erde Germany GmbH if you have any questions 		

The slew drive is preloaded in the raceway system on delivery. Over a longer period of operation, this preloading may diminish and bearing clearance open up.

Prevent damage

Wear measurements allow early detection of technical problems before they can lead to unplanned equipment downtimes. We recommend regular (every 12 months) bearing wear measurements to evaluate the slew drive raceway condition. Wear to the raceway system presents as a change in the axial motion or subsidence. This increase in wear can be ascertained by measuring the tilt clearance or subsidence. Inspection intervals should be adjusted depending on how rapidly wear develops.

Tilt clearance measurement

We recommend measuring the tilt clearance to ascertain the wear. The loading principle for such a measurement is shown in Figure 4. The measurement is taken between the lower connecting structure and the bearing ring bolted into the upper connecting structure. To minimize the effect of elastic deformation of the connecting structure, the measurement should be taken as close to the slew drive as possible.



Figure 4: Schematic depiction of tilt clearance measurement

Determination of tilt clearance

1. Position the slew drive (arm) in the main work area
2. Turn off the equipment and secure it against being turned on again
3. Make a permanent mark at the measuring position on the slew drive housing and on the worm gear (top connecting structure)
4. Attach two dial indicators => in areas "A" & "B" (Figure 4)
5. Apply the defined tilting torque in "A" direction (min. 50% of operating load) => do not twist the slew drive
6. Set both dial indicators to "zero"
7. Apply the defined tilting torque in "B" direction (min. 50% of operating load) => do not twist the slew drive.

The displayed measurement value is equal to the tilt clearance and serves as the base value for comparison with later inspections
8. Log and document all measurements

The maximum permitted bearing clearance (tilt clearance) may not exceed 2.0 mm.

Note:

If the permitted tilt clearance is exceeded, the slew drive must be shut down and replaced as safe operation can no longer be guaranteed.

1.5.4 Inspection of worm gear's circumferential backlash

Wear on the worm and bearing gear teeth increases the circumferential backlash. For this reason, the backlash must be inspected every 12 months.

If the maximum permitted circumferential backlash is reached, the slew drive must be shut down and replaced as safe operation can no longer be guaranteed.

Determining the circumferential backlash from the rotation angle

1. Position the slew drive (arm) in the main loading area.
2. Turn off the equipment and secure it against being turned on again.
3. Permanently mark the measuring position on both the housing and worm gear/toothed ring.
4. Remove the drive so that the worm shaft can easily be rotated by hand.
5. Determine the rotation angle of the worm shaft (without turning the worm gear). Make markings on the drive flange and worm gear if necessary.
6. Log and document the measurements.

All later inspections must be carried out at the same measurement location (housing/worm gear).

The rotation angle when the equipment is new can be used as a comparison for later inspections.

Gear tooth module	max. rotation angle
5	30°
6	28°
7	28°

1.5.5 Lubricant analysis

A lubricant analysis can be done in addition to the wear measurements in order to obtain more precise information about the condition of the raceway system and gearing.

These two results together allow for more accurate evaluation of wear and determination of further action.

thyssenkrupp rothe erde Germany GmbH will perform the analysis of the grease sample. Please contact us.

1.6 Disposal at end of useful life

The slew drive must be disposed of correctly and in compliance with applicable waste regulations at the end of its useful life.

WARNING	
	<p>Disposal may cause environmental hazards</p> <ul style="list-style-type: none"> • Please comply with waste regulations • Please comply with national regulations

1.7 thyssenkrupp rothe erde services

We offer the following services to ensure the continuous, uninterrupted operation of our slew drives:

Installation	Maintenance/Inspection	Repairs	Miscellaneous
Evaluation of contact surfaces / laser measurement	Wear measurement	Repairs	Training
Bearing assembly	Bolt check	General tune-up	Technical support
Reference measurement	Lubricant analysis		
Start-up	Seal replacement		

You can find more information on our website at <https://www.thyssenkrupp-rotheerde.com/de/service>

Europe

thyssenkrupp rothe erde Germany GmbH
Headquarter
44137 Dortmund
Germany
P: +49 (0) 231 1 86 0
M: rotheerde@thyssenkrupp.com
www.thyssenkrupp-rotheerde.com

Plant Lippstadt
Beckumer Str. 87
59555 Lippstadt
Germany
P: +49 (0) 29 41 7 41 0
M: rotheerde@thyssenkrupp.com

thyssenkrupp rothe erde Italy S.p.A.
Viale Kennedy, 56
25010 Visano (Brescia)
Italy
P: +39 342 866 00 10
M: mri@thyssenkrupp.com

thyssenkrupp rothe erde UK Ltd.
Peterlee, Co. Durham, SR8 2HR
Great Britain
P: +44 (0) 191 518 5600
M: sales@roballo.co.uk

thyssenkrupp rothe erde Slovakia a.s.
Robotnícka ul.
01701 Považská Bystrica
Slovakia
P: +421 42 4371 111
M: pslpb@pslas.com

thyssenkrupp rothe erde Spain S.A.
Carretera Castellón, km. 7
Polígono Industrial "La Cartuja"
50720 Zaragoza
Spain
P: +34 (9 76) 50 04 80
M: roteisa@roteisa.es

Asia

thyssenkrupp rothe erde (Xuzhou)
Ring Mill Co. Ltd.
Luoshan road 6
Xuzhou Economic and Technological
Development Zone
Jiangsu, 221004
China
P: +86 (5 16) 87 98 01 01
M: sales@xrem.cn

Xuzhou rothe erde
Slewing Bearing Co. Ltd.
Luoshan Road 15
Xuzhou Economic and Technological
Development Zone
Jiangsu, 221004
China
P: +86 (5 16) 87 76 71 70
M: sales@xreb.com

Rothe Erde India Private Ltd.
Gat No. 429,
Village: Wadivarhe, Post: Gonde,
Taluka: Igatpuri, District: Nashik,
Maharashtra, PIN 422 403
India
P: +91 (25 53) 30 22 31
M: info.rotheerdeindia@thyssenkrupp.com

thyssenkrupp rothe erde Japan Ltd.
Kyobashi Takaracho PREX 7F,
3-5 Hacchobori 4-chome,
Chuo-ku, Tokyo 104-0032
Japan
P: +81-(0)3-6228-3388
M: info@roballo.co.jp

America

thyssenkrupp Brasil Ltda. –
Division rothe erde
Rua Lidia Blank, No. 48
CEP 09913-010 Diadema, São Paulo
Brasil
P: +55 (11) 40 55 84 00
M: vendas.tkgb@thyssenkrupp.com

thyssenkrupp rothe erde USA Inc.
1400 South Chillicothe Rd.
P.O. Box 312
Aurora, Ohio 44202
USA
Tel.: +1 (3 30) 5 62 40 00
M: sales@tkreusa.com